

### General Description

The Digital Blocks DB-I2C-MS-AXI Controller IP Core interfaces a microprocessor via the AMBA AXI Bus to an I2C Bus in Standard-Mode (100 Kbit/s) / Fast-Mode (400 Kbit/s) / Fast-Mode Plus (1 Mbit/s) / Hs-Mode (3.4+ Mb/s) / Ultra Fast-Mode (5 Mbit/s).

The DB-I2C-MS-AXI Controller IP Core can also interface a set of Registers within an ASIC / ASSP / FPGA device as well as interface Memory (e.g. SDRAM / SRAM / FLASH) to an I2C Bus.

The I2C is a two-wire bidirectional interface standard (SCL is Clock, SDA is Data) for transfer of bytes of information between two or more compliant I2C devices, typically with a microprocessor behind the master controller and one or more slave devices.

The DB-I2C-MS-AXI is a Master / Slave I2C Controller that in Master Mode controls the Transmit or Receive of data to or from slave I2C devices while in Slave Mode allows an external I2C Master device to control the Transmit or Receive of data.

In an ASIC / ASSP / FPGA integrated circuit, typically, the microprocessor is an ARM processor, but can be any embedded processor. Figure 1 depicts the system view of the DB-I2C-MS-AXI Controller IP Core embedded within an integrated circuit device with its Microprocessor Configuration.

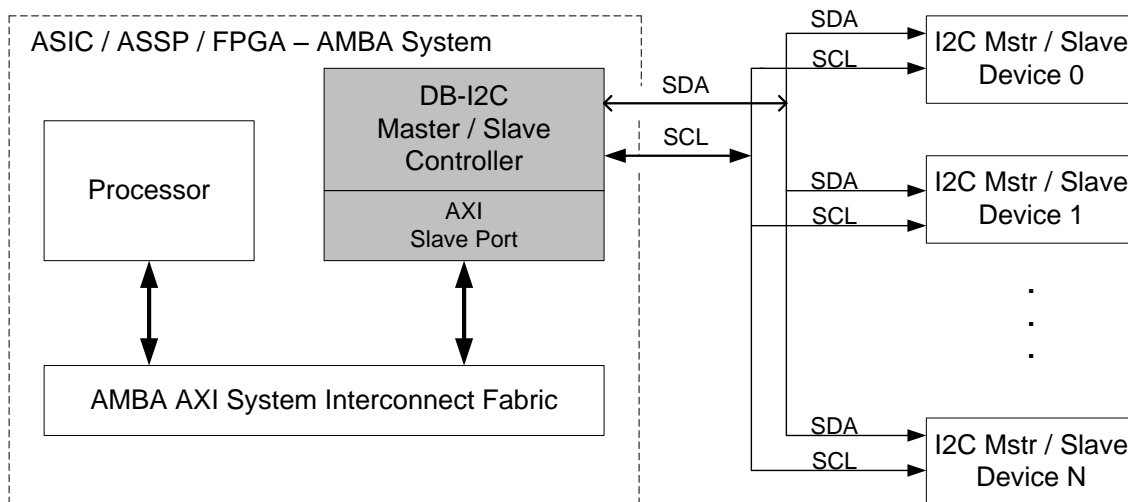

Figure 1: DB-I2C-MS-AXI Controller – System Diagram

The DB-I2C-MS-AXI Controller IP Core targets embedded processor applications with higher performance algorithm requirements or I2C transfer requirements to a set of Registers or Memory. While most I2C controllers require high processor interaction

involvement, the DB-I2C-MS-AXI contains a parameterized FIFO and Finite State Machine Control for the processor to off-load the I2C transfer to the DB-I2C-MS-AXI Controller. Thus, while the DB-I2C-MS-AXI in Master Mode is busy, independently controlling the I2C Transmit or Receive transaction of data, or in Slave Mode, allowing the external I2C Master device to control the Transmit or Receive of data, the processor can complete other tasks. All Master & Slave Mode Transmit / Receive transfers are with respect to the internal FIFO, thus fully isolating the processor from the I2C transfer of a block of data.

## Features

- Master / Slave I<sup>2</sup>C Controller Modes:
  - Master – Transmitter
  - Master – Receiver
  - Slave – Transmitter
  - Slave – Receiver
- Supports following I2C bus speeds:
  - Hs-Mode (3.4+ Mb/s)
  - Ultra Fast-Mode (5 Mb/s)
  - Fast Mode Plus (1 Mb/s)
  - Fast Mode (400 Kb/s)
  - Standard Mode (100 Kb/s)
- I2C compliant features:
  - Multi-Master, Clock Synchronization, Arbitration, SCL held low by Slave, Repeated Start, 7/10-bit addressing, & General Call Addressing
- Parameterized FIFO memory for off-loading the I<sup>2</sup>C transfers from the processor:
  - Targets embedded processors with higher performance algorithm requirements, by the I<sup>2</sup>C Controller independently controlling the Transmit or Receive of bytes of information buffered to and from a FIFO.
- System-level features & integration capabilities:
  - CPU Interface via parameterized FIFO with support for APB / AHB / AXI / AXI-lite / Avalon SoC Interconnect fabrics
  - Enhanced SCL / SDA spike filtering capabilities
  - Enhanced Repeated Start capabilities
- Optional system-level features & integration capabilities:
  - DMA transfer between the I2C Bus & Memory (SDRAM / SRAM / FLASH)
  - Direct interface to user Registers within ASIC / ASSP / FPGA device, for Master/Slave transfer across the I2C Bus
  - Remote Configuration of a Digital Blocks' I2C Slave by an I2C Master
  - SMBus Support:
    - SMBus Timeout
    - SMBus Alert
    - SMBus Data minimum hold time

- 13 sources of internal interrupts with masking control
- Compliance with AMBA and I2C specifications:
  - Compliance with AMBA AXI Protocol Specification (V2.0)
  - Philips/NXP – The I2C-Bus Specification, Version 2.1, January 2000 and UM10204 Rev 6 – 4 April 2014
- Fully-synchronous, synthesizable Verilog RTL core, with rising-edge clocking, no gated clocks, and no internal tri-states, for easy integration into FPGA or ASIC design flows.

## Pin Description

In addition to the AMBA AXI Bus interfaces, which include the input CLOCK and RESET signals and the output INTR (interrupt) signal, the I2C interface signals are listed in Table 1.

Name	Type	Description
<b>I2C Bus interface</b>		
SDAI	Input	Serial Data
SDAO	Output	Serial Data
SCLI	Input	Serial Clock Line
SCLO	Output	Serial Clock Line

**Table 1: DB-I2C-MS-AXI – I/O Pin Description**

## Verification Method

The DB-I2C-MS-AXI Controller IP Core contains a verification test suite with AMBA AXI Bus functional models that program the DB-I2C-MS-AXI control & status registers, generates & sends I2C data, monitors the I2C bus protocol, and checks expected results.

The DB-I2C-MS-AXI Controller IP Core has internally been verified as follows:

- Instantiated within an FPGA, controlled by an ARM processor, and communicating with (1) I2C Master and I2C Slave merchant semiconductor devices, including devices from NXP; and (2) variety of ASICs containing I2C Master & Slave bus interfaces

## Customer Evaluation

Digital Blocks offers a variety of methods for prospective customers to evaluate the DB-I2C-MS-AXI. Please contact Digital Blocks for additional information.

## **Deliverables**

The DB-I2C-MS-AXI is available in synthesizable RTL Verilog or VHDL or a technology-specific netlist for FPGAs, along with Synopsys Design Constraints, a simulation test bench with expected results, datasheet, and user manual.

The DB-I2C-MS-AXI comes along with example C code software for controlling Transmit and Receive Transactions in an Eclipse-based ARM Integrated Development Environment (IDE).

## **Ordering Information**

Please contact Digital Blocks for additional technical, pricing, evaluation, and support information.

Digital Blocks, Inc.  
PO Box 192  
587 Rock Rd  
Glen Rock, NJ 07452 USA  
Phone: +1-201-251-1281  
eFax: +1-702-552-1905  
[info@digitalblocks.com](mailto:info@digitalblocks.com)

Copyright © Digital Blocks, Inc. 2007 - 2016, ALL RIGHTS RESERVED

###

Digital Blocks is a registered trademark of Digital Blocks, Inc.  
All other trademarks are the property of their respective owners