

### General Description

The Digital Blocks DB-I2C-S-AHB Controller IP Core interfaces an ARM, MIPS, PowerPC, ARC or other high-performance microprocessor via the AMBA 2.0/3.0 AHB System Interconnect Fabric to an I2C Bus. The I2C is a two-wire bidirectional interface standard (SCL is Clock, SDA is Data) for transfer of bytes of information between two or more compliant I2C devices.

The DB-I2C-S-AHB is a Slave I2C Controller that controls the Transmit or Receive of data to or from external Master I2C devices. Figure 1 depicts the system view of the DB-I2C-S-AHB Controller IP Core embedded within an integrated circuit device.

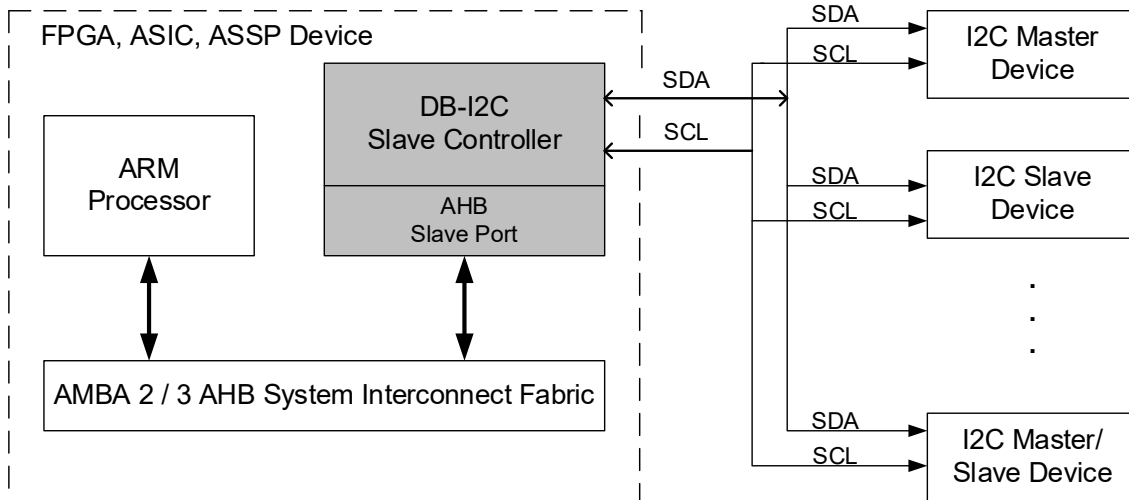

Figure 1: DB-I2C-S-AHB Controller – System Diagram

The DB-I2C-S-AHB Controller IP Core targets embedded processor applications with higher performance algorithm requirements. While most I2C controllers require high processor interaction involvement, the DB-I2C-S-AHB contains a parameterized FIFO and Finite State Machine control for the processor to off-load the I2C transfer to the DB-I2C-M-AHB Controller. Thus, while the DB-I2C-S-AHB is busy, independently controlling the I2C Transmit or Receive transaction of data, the processor can go off and complete other tasks. Note that the Slave only capability of the DB-I2C-S-AHB adds to its small VLSI footprint requirements.

The DB-I2C-S-AHB could be paired with the DB-I2C-M-AHB or DB-I2C-MS-AHB in another ASIC/ASSP/FPGA, for robust & VLSI efficient transfer of blocks of data.

## Features

- Slave I<sup>2</sup>C Controller Modes:
  - Slave – Transmitter
  - Slave – Receiver
- Supports four I2C bus speeds:
  - Hs-Mode (3.4+ Mb/s)
  - Fast Mode Plus (1 Mbit/s)
  - Fast Mode (400 Kb/s)
  - Standard Mode (100 Kb/s)
  - Ultra Fast-mode (5 Mbit/s)
- Parameterized FIFO memory for off-loading the I<sup>2</sup>C transfers from the processor:
  - Targets embedded processors with higher performance algorithm requirements, by the I<sup>2</sup>C Controller independently controlling the Transmit or Receive of bytes of information buffered to and from a FIFO.
- I2C compliant features:
  - Repeated Start, 7/10-bit addressing, General Call Addressing, & SCL Low Wait States
- Enhanced system-level features & integration capabilities:
  - CPU Interface via parameterized FIFO with support for APB / AHB / AXI / AXI-lite / Avalon interconnect fabrics
  - Enhanced SCL / SDA spike filtering capabilities
  - Enhanced Repeated Start capabilities
- Enhanced system-level features & integration capabilities (OPTIONAL):
  - DMA transfer between the I2C Bus & Memory (SDRAM / SRAM / FLASH)
  - Direct interface to user Registers within ASIC / ASSP / FPGA device, for Master/Slave transfer across the I2C Bus
  - Remote Configuration of a Digital Blocks' I2C Slave by an I2C Master
- 8 sources of internal interrupts with masking control
- Compliance with AMBA 2.0/3.0 and I2C specifications:
  - AMBA Specification (Rev 2.0/3.0), AHB Bus
  - Philips/NXP – The I2C-Bus Specification, Version 2.1, January 2000 and UM10204 Rev 7 – 1 Oct 2021
- Fully-synchronous, synthesizable Verilog RTL core, with rising-edge clocking, no gated clocks, and no internal tri-states, for easy integration into FPGA or ASIC design flows.

Digital Blocks offers I2C Master/Slave, Master-only, and Slave-only Controller IP supporting Hs-Mode / Fast Mode Plus / Fast Mode / Standard Mode.

## Pin Description

In addition to the AMBA AHB Bus interfaces, which include the input AHB CLOCK and RESET signals and the output INTR (interrupt) signal, the I2C interface signals are listed in Table 1.

Name	Type	Description
<b>I2C Bus interface</b>		
SDAi	Input	Serial Data
SDAo	Output	Serial Data
SCLi	Input	Serial Clock Line

**Table 1: DB-I2C-S-AHB – I/O Pin Description**

## Verification Method

The DB-I2C-S-AHB Controller IP Core contains a test suite that generates & sends I2C transactions, monitors the I2C bus protocol, and checks expected results.

The DB-I2C-S-AHB Controller IP Core has internally been verified as follows:

- Instantiated within an FPGA, and communicating with NXP I2C Master IP Controller, and A ARM processor for expected data checking. I2C Bus Compliance testing with lab instrumentation.
- Instantiated within an FPGA, and communicating with Digital Blocks I2C Master IP Controller, and A NIOS II processor for expected data checking.
- Internal projects interfacing to NXP, Atmel I2C Masters.
- Customer FPGA / ASIC implementations.

## Customer Evaluation

Digital Blocks offers a variety of methods for prospective customers to evaluate the DB-I2C-S-AHB. Please contact Digital Blocks for additional information.

## Deliverables

The DB-I2C-S-AHB is available in synthesizable RTL Verilog or a technology-specific netlist for FPGAs, along with Synopsys Design Constraints, a simulation test bench with expected results, datasheet, and user manual.

## Ordering Information

Please contact Digital Blocks for additional technical, pricing, evaluation, and support information.

Digital Blocks, Inc.  
PO Box 192  
587 Rock Rd  
Glen Rock, NJ 07452 USA  
Phone: +1-201-251-1281  
eFax: +1-702-552-1905  
[info@digitalblocks.com](mailto:info@digitalblocks.com)

Copyright © Digital Blocks, Inc. 2007 - 2022, ALL RIGHTS RESERVED

###

Digital Blocks is a registered trademark of Digital Blocks, Inc.  
All other trademarks are the property of their respective owners