

General Description

The Digital Blocks DB-UDP-IP-25GbE-AMBA is a UDP/IP Hardware Stack / UDP Off-load Engine (UOE) with low latency, high-performance targeting 25 GbE network links. The DB-UDP-IP is a Verilog SoC IP Core targeting Intel/Altera and Xilinx FPGAs and ASIC/ASSP devices.

Figure 1 depicts the UDP/IP Hardware Stack SoC IP Core embedded within an Altera / Xilinx FPGA device, connected on one side to a 25 GbE Ethernet MAC, and on the other side to the user application within the FPGA (i.e. either the FPGA logic fabric or embedded host processor).

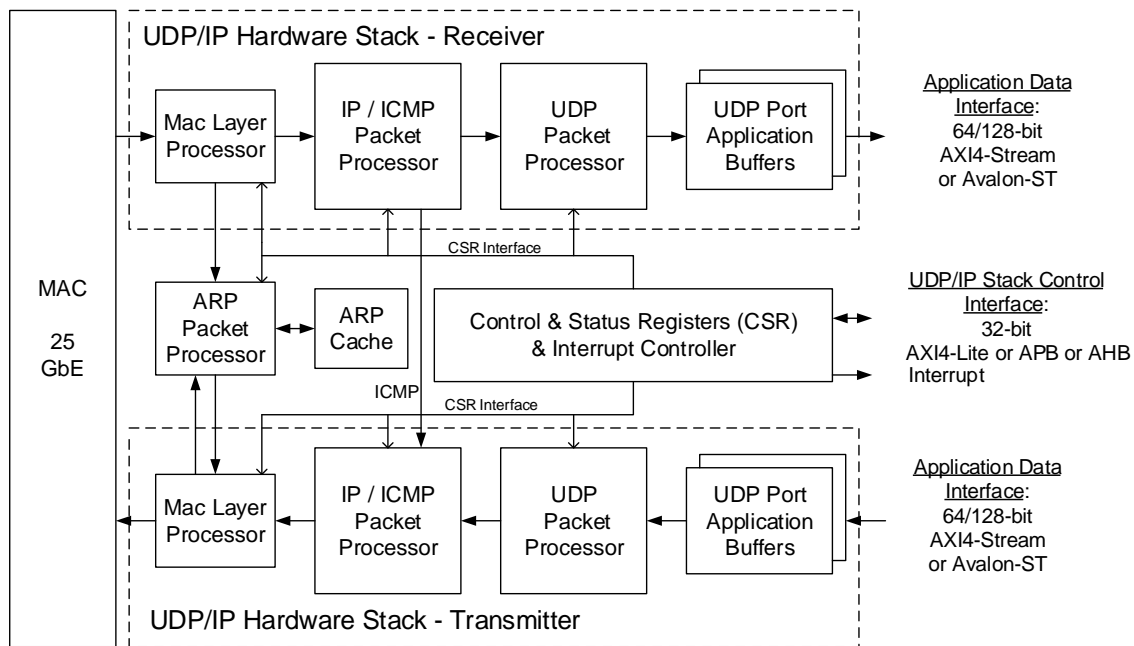

Figure 1: DB-UDP-IP-25GbE-AMBA - Verilog SoC IP Core

Features

- 25 GbE network links
- Low latency, high-performance wire-line performance
- Internet Protocol (IP) Packet Processor:
 - IP & ICMP (Internet Control Message Protocol) Protocol
 - Host IP address filter, IP header checksum check & generator, user-selectable Maximum Transmission Unit (MTU), Unicast & Multicast Packet support
 - Compliance with IETF IPv4/IPv6 RFCs
- User Datagram Protocol (UDP) Packet Processor:
 - Support for up to 256 UDP Ports
 - UDP header checksum check & generator
 - Compliance with IETF UDP RFCs
- Address Resolution Protocol (ARP) Packet Processor (client/server) with 4-16 entry ARP cache
- VLAN Support, DHCP, IGMP, Jumb Frames
- Interface to Intel/Altera (Avalon-ST) & Xilinx & Synopsys 25G MAC
- High Speed Data Interface to user Host Application:
 - 64-bit / 128-bit AXI4-Stream
- Host set-up & control via Control & Status Registers and Interrupt Controller
 - 32-bit AXI4-Lite or APB or AHB
- Pipeline, High Clock Rate, Low Latency architecture & design
- Fully-synchronous, synthesizable RTL Verilog SoC IP core

Design Services

The Digital Blocks offers design services incorporating the UDP/IP Hardware Stack / UDP Off-load Engine (UOE) SoC IP Core targeting Xilinx or Intel/Altera FPGAs. Digital Blocks offers customization features, per customer requirements. Please contact Digital Blocks for additional information.

Customer Evaluation

Digital Blocks offers a variety of methods for prospective customers to evaluate the UDP/IP Hardware Stack UDP Off-load Engine (UOE) SoC IP Core. Please contact Digital Blocks for additional information.

Deliverables

The DB-UDP-IP IP Core is available in synthesizable RTL Verilog or a technology-specific netlist for FPGAs, along with Synopsys Design Constraints, a simulation test bench with expected results, datasheet, and user manual.

Ordering Information

Please contact Digital Blocks for additional technical, pricing, evaluation, and support information.

Digital Blocks, Inc.
PO Box 192
587 Rock Rd
Glen Rock, NJ 07452 USA
Phone: +1-201-251-1281
eFax: +1-702-552-1905
info@digitalblocks.com

Copyright © Digital Blocks, Inc. 2012-2020, ALL RIGHTS RESERVED

###

Digital Blocks is a registered trademark of Digital Blocks, Inc.
All other trademarks are the property of their respective owners