

General Description

The Digital Blocks DB9000AXI3 Display Controller IP Core interfaces a microprocessor and frame buffer memory via the AMBA AXI Protocol Interconnect to a LCD or OLED display panel.

The Display Controller Verilog RTL IP Core comes in releases supporting baseline display processing features and releases with advanced display processing, such as Multi-layer Overlay Windows with optional Alpha Blending, Scaling, Color Space Conversion, 4:2:0 and 4:2:2 YCrCb with Re-sampling & conversion to RGB, and Hardware Cursor and Frame Buffer Compression. Optional features provide the customer with targeted features while saving on VLSI resources and licensing costs.

The DB9000AXI3 contains a selectable 256 / 128 / 64 / 32-bit AXI Master Interface with the higher data widths targeting higher resolution, higher color depth LCD or OLED display panels, with their resulting high frame buffer memory data bandwidth requirements.

The DB9000AXI3 IP Core can be implemented in an ASIC, ASSP, or FPGA device with an embedded microprocessor, an AMBA AXI Interconnect fabric, and SDRAM Controller for access to frame buffer memory. Typically, the microprocessor is an ARC, ARM, Intel, MIPS, OpenSPARC, PowerPC, RISC-V, or Tensilica processor and frame buffer memory is off-chip DDR 1-5 SDRAM.

Figure 1 depicts the system view of the DB9000AXI3 Display Controller IP Core embedded within an integrated circuit device.

System View - Block Diagram

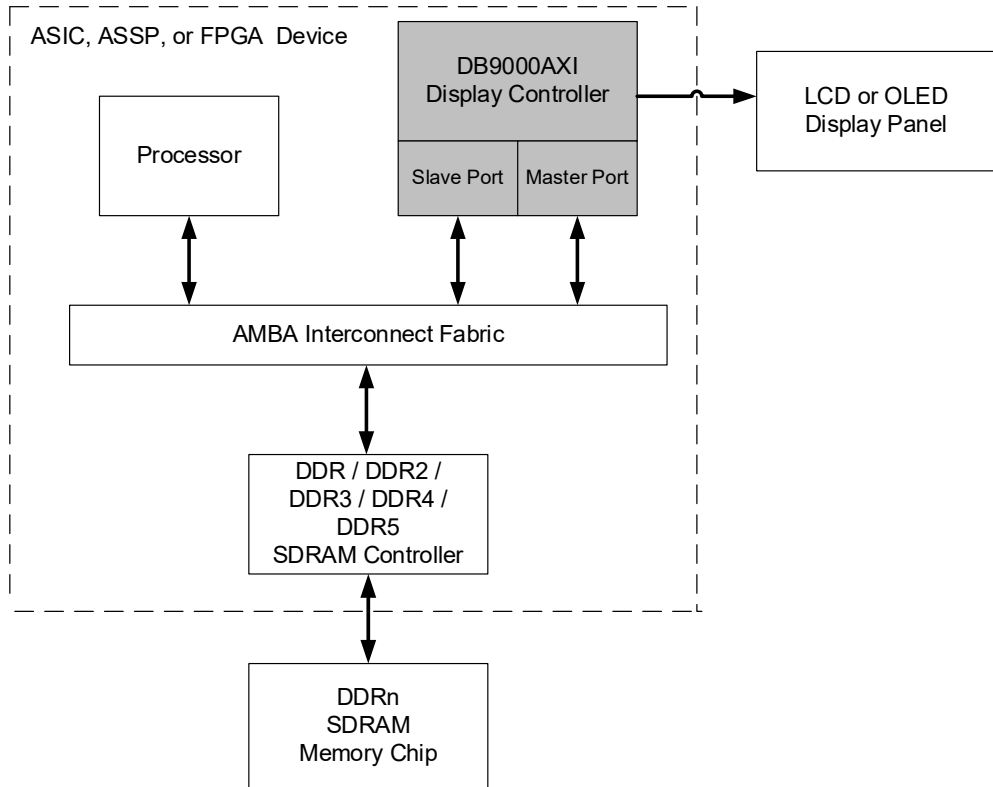

Figure 1: DB9000AXI Display Controller – System Diagram

Features

- Wide range of programmable Display Panel resolutions:
 - From Quarter VGA up to 1920x1080 HD, 4K, and 8K
- Releases supporting baseline display requirements and releases with following optional display processing features:
 - Overlay Windows with additional options:
 - Alpha Blending
 - Scaling
 - Color Space Conversion (CSC)
 - 4:2:0 and 4:2:2 YCrCb with Re-sampling & CSC to RGB
 - Programmable size, placement, & format
 - Hardware Cursor
 - Frame Buffer Compression
- Color Palette RAM per layer or single Palette for integrated display image
- Interface to parallel RGB, LVDS, HDMI, DisplayPort, MIPI, Vby1, BT.656
- Programmable 1,2,4,8 Port Display Panel interfaces
- Programmable horizontal & vertical timing parameters:
 - front porch, back porch, sync width, pixels-per-line, lines-per-panel
 - horizontal & vertical sync polarity
- Programmable frame buffer bits-per-pixel (bpp) color depths:
 - 1, 2, 4, 8 bpp mapped through Color Palette
 - 16, 18, 24 bpp non- Palette
- AMBA AXI / AHB / APB Interconnect:
 - Selectable 256 / 128 / 64 / 32-bit AXI Master Port for DB9000AXI3 DMA access of frame buffer memory for driving the display
 - Selectable 256 / 128 / 64 / 32-bit AXI (or AHB / APB) Slave Port for control & status interface to microprocessor
- Power up and down sequencing support
- 15 sources of internal interrupts with masking control
- Little-endian, big-endian, or Windows CE mode
- Linux OS driver
- Fully-synchronous, synthesizable Verilog RTL core, with rising-edge clocking, No gated clocks, and No internal tri-states.

Display Resolution Support - Additional Information

- Example Display Panel high resolutions:
 - Digital Cinema Systems (DCI) 2048 x 1080 2K image, 4096 x 2160 4K image, & Cinema Scope HD 2560 x 1080
 - 7680x4320, 4096x2560, 3840x2160, 2560x2048, 2048x2048, 2048x1536, 1920x1200, 1920x1080, 1680x1050, 1600x1200
 - 1600x900, 1440x900, 1366x768, 1280x1024, 1280x768, 1080x1920, 1024x768, 1024x600, 1024x576, 960x540, 800x600, 800x480
- Example Display Panel medium / small resolutions:
 - 640x480, 640x400, 640x240, 640x200, 480x800, 480x640, 480x272
 - 480x234, 240x400, 240x320, 240x240, 320x200, 320x240

Display Controller - Block Diagram

Figure 2 depicts the DB9000AXI3 Display Controller IP release supporting baseline display processing features. Contact Digital Blocks. Contact Digital Blocks regarding optional advanced display processing features.

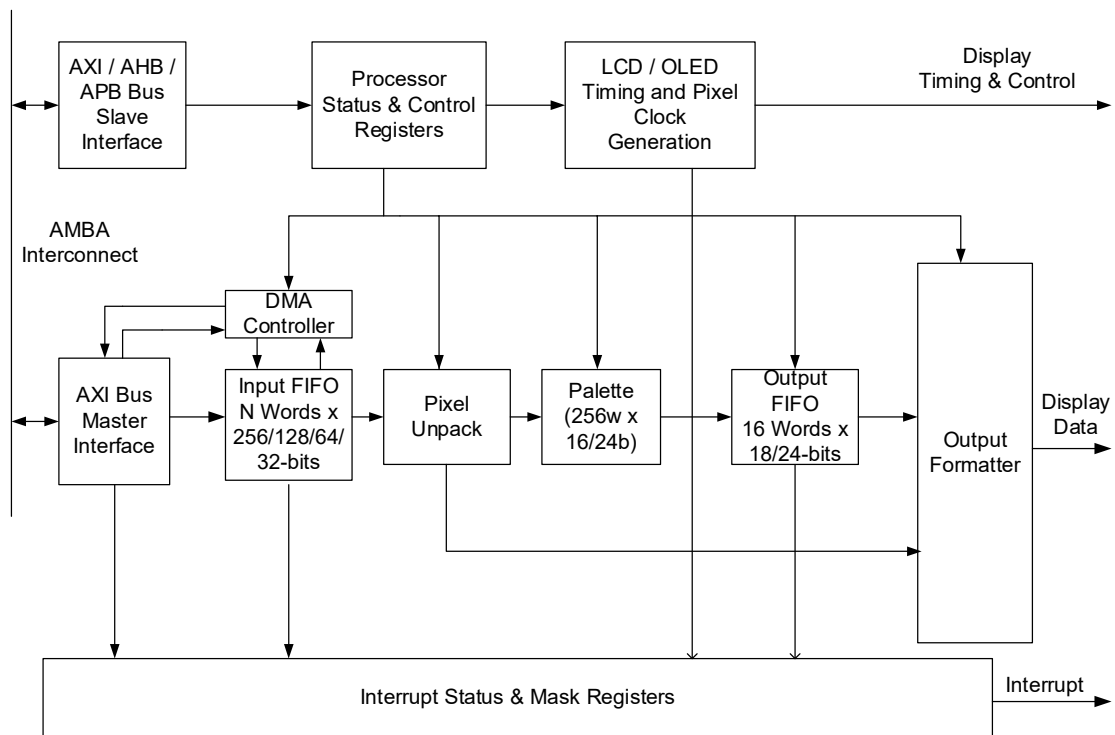

Figure 2: DB9000AXI AMBA Interconnect Display Controller

Verification Method

The DB9000AXI3 contains a simulation test suite with AXI Bus functional models that program the DB9000AXI3 control & status registers via the AXI/AHB/APB Slave Bus, generates frame buffer data in response to AXI Master requests, and checks expected results.

Customer Evaluation

Digital Blocks offers a variety of methods for prospective customers to evaluate the DB9000AXI3. Please contact Digital Blocks for additional information.

Deliverables

The DB9000AXI3 is available in synthesizable RTL Verilog, along with a simulation test bench with expected results, datasheet, and user manual.

Ordering Information

Please contact Digital Blocks for additional technical, pricing, evaluation, and support information.

Digital Blocks, Inc.
PO Box 192
587 Rock Rd
Glen Rock, NJ 07452 USA
Phone: +1-201-251-1281
eFax: +1-702-552-1905
info@digitalblocks.com

Copyright © Digital Blocks, Inc. 2007-2022, ALL RIGHTS RESERVED

###

Digital Blocks™ is a trademark of Digital Blocks, Inc.
ARM and AMBA are registered trademarks of ARM Limited.